



XENOptics CSOS-72 / CSOS-144 Remote Fiber Management

REMOTE FIBER MANAGEMENT

The XENOptics Remote Compact Smart Optical Switch (CSOS-72S-LC and CSOS-144D-LC) breaks new ground by replacing manual optical patch panels with remotely managed and fully automated, robotic patching systems.

This new compact system is part of XENOptics's XSOS product family which introduced robotic fiber automation to the industry. The small form factor CSOS allow efficient remote management of fiber networks, even for operators who manage small/medium-sized networks or complex networks that require fiber management at each top of a rack. The foundation of the CSOS solution is XENOptics patented 3D optical switching (3D-OS) topology which delivers superb optical performance and complete traffic protection. In addition, the compact family of CSOS products were developed to support Outside Plant (OSP) environmental conditions, for example inside a street cabinet.

Full remote fiber management with CSOS allows all reconfiguration, monitoring, troubleshooting and maintenance operations to be carried out remotely, and instantly. This delivers dramatically lower total cost of ownership of the fiber infrastructure, rapid return on investment, and improved SLAs to internal or external customers while reducing operational costs.

APPLICATIONS

- Enterprise data center
- Server farms & clouds computing
- Telecom Central Office Management
- 5G Cellular networks
- Remote long-haul CO management
- End-to-End Network Management
- Remote Fiber Test System
- Wavelength Management
- Power and Utility networks
- Internet exchanges and carrier hotels
- MDU distribution
- Laboratories and testing systems

WITH CSOS:

- Remotely manage your network, lowering staff costs
- Automate testing & provisioning, improving SLAs
- Create an agile fiber network, ready for tomorrow's challenges



▲ CSOS-72S-LC



▲ CSOS-144D-LC

SYSTEM ARCHITECTURE

The CSOS-72S and CSOS-144D comprise of 2 modules: **Optical Fiber Switch (OFS)** and **Main Control Unit (MCU)**.

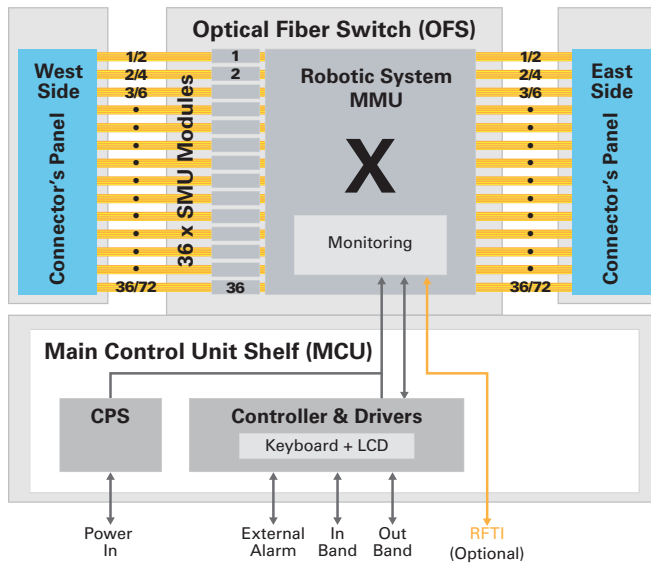

Optical Fiber Switch (OFS)

It offers breakthrough functionality by enabling remote, non-blocking switching capabilities.

Unlike other solutions XENOptics's OFS matrix features three main advantages:

- **Cost-Effective:** Reduced product cost to a level of direct competition with the manual systems.
- **Phenomenal Density:** the unique 3D-OS patentpending technology saves space is able to manage many fibers in small space.
- **High Reliability:** All the components used by XENOptics are of the highest level of quality. XENOptics has signed technology partnerships with major high-end global vendors to supply, assemble, test and support key components in the field.

The 3D-OS robotic system combines active switching with a passive latching mechanism, enabling automated provisioning and configuration while ensuring traffic flow during field replacement operations. All provisioned services will remain active due to our passive latching mechanism.

In addition, the OFS comprises of the following 2 main modules: a single MMU (Main Manipulator Unit) and 36 fiber modules, SMUs (Slack Management Unit). The MMU is an accurate robotic manipulator that grips the internal fiber connectors of the SMUs to perform the connection or dis-connection activities. Each SMU

CSOS-FAMILY INTERFACES

Parameter	Unit
Serial	RS-232 interface for local or maintenance operation.
In Band	Standard SNMP interfaces into XENOptics' Element/Network to manage the whole network. HTTP, HTTPS, SNMPv2/v3, Telnet, SSH, TFTP, NTP and Restful API.
Out of Band	Standard SNMP interfaces to be connected and managed by higher SW layers.
Power In	<ul style="list-style-type: none"> • 110 / 220 Volt AC interface • (Optional) Dual feed power 48V input for main CO power source and backup CO source
External Alarm	6 ports: 4 x dry contact inputs, 2 dry contact outputs (normally closed).
Keypad	A small status display to control the system locally.
System Status Indication	Green, yellow, red LEDs to indicate the status of the system: Normal, Warning, Alarm.
Power On	LED on the power supply indicates status.

supports 2/4 optical ports. It is accompanied by a remote diagnostics camera that identifies each one of the optical elements, environmental, vibration, positioning and dust sensors and a dust cleaning extraction unit to maintain high optical performance.

Main Control Unit (MCU)

This controls all switching elements. It monitors real-time status of cross-connections and network performance. It also transmits data and alarms to the central network management system. It provides in-band and out-band functionality with Telnet, SSH, Restful API and SNMP interfaces.

The MCU comprises of the following modules:

- Replaceable power supply of 110-220AC (- 48 DC optional).
- Real time controller, strong processing unit and drivers to support the MMU.

MANAGEMENT

- **Web Graphical User Interface:** Displays a simple and intuitive interface for controlling the CSOS and XSOS platforms from standard desktop browsers and mobile IOS/Android devices.
- **Local Terminal Management:** Provides a simple interface to a dumb terminal with a command line interface that is primarily used in installation and maintenance modes by technicians during unit servicing.
- **Element Management System (EMS):** Offers an overall system view, topology connectivity and provisioning of the overall fiber infrastructure, system by system, interfaced through the equipment using Restful API and SNMP interface.
- **Network Management System:** Provides full network view and supports end-to-end operations using Restful API and SNMP interfaces.
- **Power-independent Traffic:** Latching mechanism consumes power only while switching and maintains traffic transmission in the event of power failure.
- **Cost-Effective:** Efficient architecture enables low cost per port.
- **High single-mode Optical Performance:** Maintains uniform insertion loss of < 1.0dB and return loss up to < -55 dB (UPC) or < -65 dB (APC).
- **Field Replacement:** All modules safely, without traffic interruption.
- **Carrier-Class System:** Meets applicable Telcordia and ITU recommendations. Highly reliable field-proven system units.
- **High Density:** Based on 3D-OS technology which provides unique fiber density and allows fiber port management of 100s of ports using a compact side solution mounted in a standard 19" rack.
- **Standard Software Interfaces:** WEB Graphical User Interface. SDN compliant Restful API. SNMP equipment interfaces.
- **Synchronized Database:** Configurations immediately reflected in management system and recovered automatically in case of failure.
- **Ruggedized Outside Plant (OSP)** housing option for installation in street cabinets in harsh environment of -40°C and up to +65°C.

CSOS-72/144 FEATURES

- **Optical Switching:** Non-blocking 72 or 144 fibers based on "East-West" architecture. CSOS-72SLC supports 36x36 simplex ports with 72 optical adaptors, LC type. CSOS-144D-LC supports 72x72 based on duplex ports with 72 optical duplex adaptors (144 ports), LC type.

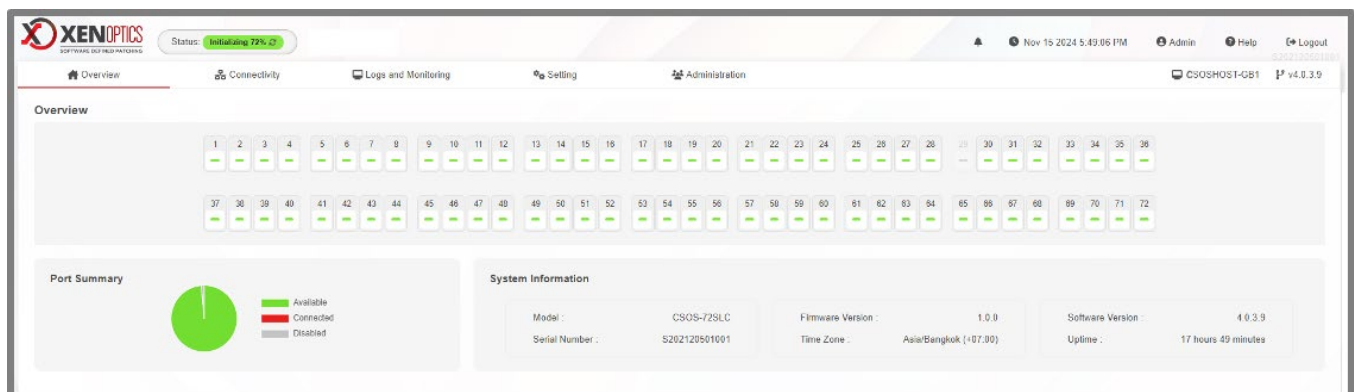

▲ Web Graphical User Interface

SPECIFICATIONS

Parameter	Unit	Min	Typical	Max
OPTICAL CHARACTERISTICS				
Operating Range	nm	1260		1630
Insertion Loss (spliced version)	dB		0.60	1.0
Insertion Loss (connectorized version)	dB		0.50	1.0
Insertion Loss Repeatability	dB		0.06	0.1
Crosstalk	dB			-70
Return Loss (UPC/APC)	dB			-55 / -65
PDL	dB			0.15
PMD	psec			0.1
Input Power	dBm			25
Switching Time	Sec		36	60
POWER REQUIREMENTS				
Input Voltage	V _{DC}		110-220	
Input Voltage (optional)	V _{DC}	-40		-75
Power Consumption (switching Operation)	W			50
Power Consumption (standby)	W			6
Power Consumption (sleep mode for OSP)	W	0.1		0.5
ENVIRONMENTAL CONDITIONS				
Temperature Range	°C	-5		+45
Temperature Range (street cabinet)	°C	-40		+65
Temperature Range (Transport)	°C	-40		+70
Relative Humidity	%	10		95
RELIABILITY				
Service Lifetime	Years	20		
DIMENSIONS				
CSOS-72S and CSOS-144D (mm)	Height: 90	Width: 450	Depth: 500 and 525	
Weight	11.8 Kg			
Applicable Standards				
Environmental	ETSI 300019 CLASS 3.2			
EMC	EN 55022 CLASS B, IEC 1000-4-2-6			
Safety	EN 60950, IEC 825-1; IEC 825-2, GR-1089-CORE			
ESD	IEC-61000-4-2			
EU Environmental	ETS-300 019			
US Environmental	NEBS 3, GR-63-CORE			



Supplied and supported in the UK & Ireland by **Red Helix**
 Tel: 01296 397711 | Email: info@redhelix.co.uk | Web: www.redhelix.co.uk



Connect with us: www.xenoptics.com | info@xenoptics.com

Thailand
 195 M3 Bypass Chiangmai-Handong
 T. Namphrae, A. Handong, Chiang Mai, 50230
 (+66) 052 081 400

© 2025 XENOptics. All rights reserved. XENOptics logos are trademarks, and copyright of XENON Systems Pty Ltd. All rights reserved. All other trademarks are the property of their respective owners. Technical information is subject to change without notice. XENOptics CSOS-72-144 Product brief - BRO6C.pdf